



M+S HYDRAULIC

M+S Hydraulic is a leading manufacturer of hydraulic motors, steering units, valves, brakes and accessories. The company is ISO 9001:2000 certified by TUV for guaranteeing quality production and high technology



MLHM



MLHP



MLHR

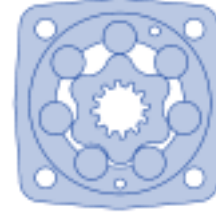

MLHS



MLHT

M+S Hydraulic

No.	ORBITAL MOTOR ดรอกลิค	มอเตอร์ไฮ	Disp.	Speed(rpm)	Pressure(bar)
			cc/rev	cont. - int.	cont. - int. - peak.
1	MLHP 100 M2U E/MS	(MP 100)	99	612 - 765	140 - 175 - 225
2	MLHP 160 M2U E/MS	(MP 160)	158.4	382 - 479	140 - 175 - 225
3	MLHR 80 M2U E/MS	(MR 80)	80.3	750 - 940	175 - 200 - 225
4	MLHR 100 M2U E/MS	(MR 100)	99.8	607 - 758	175 - 200 - 225
5	MLHR 160 M2U E/MS	(MR 160)	159.6	379 - 474	175 - 200 - 225
6	MLHR 200 M2U E/MS	(MR 200)	199.8	303 - 379	140 - 175 - 225
7	MLHR 250 M2U E/MS	(MR 250)	250.1	240 - 303	110 - 175 - 225
8	MLHS 160 G2U D/MS	(MS 160)	159.7	470 - 560	205 - 225 - 225
9	MLHS 160 G6 D/MS	(end ports)	159.7	470 - 560	205 - 225 - 225
10	MLHS 160 M2 D		159.7	470	205 - 225
11	MLHS 200 G6 D/MS	(end pots)	200	375 - 450	160 - 210 - 225
12	MLHS 200 M2 D		200	375	160 - 210
13	MLHSY200G6UD/MS	(end pots)	397	185 - 225	160 - 175 - 200
14	MLHS 250 M2 D		250	300	140 - 175
15	MLHS 315 M2 D		314.9	240	120 - 140
16	MLHS 400 M2 D		397	190	100 - 120
17	MLHSY400G6UD/MS	(end pots)	397	185 - 225	160 - 175 - 200

STEERING UNIT พวงมาลัยไฮดรอลิค Built-in Relief and Check Valve, Non Load Reaction

18	HKUS 100/4-125/MS	(OSPC 100)	99	10 L	160
19	HKUS 160/4-125/MS	(OSPC 160)	158.4	16 L	160
20	HKUS 320/4-125/MS	(OSPC 320)	316.8	32 L	160
21	HKUS 400/4-125		396	40L	160

STEERING COLUMNS TYPE KK

22	KK 150 I PC/MS		Length 150 mm.		
----	----------------	--	----------------	--	--

SHAFT SEAL RING

23	HKUS-MP015V001/MS		for HKUS		
24	HKUS-MP013V007/MS		DUST SEAL RING FOR HKUS		
25	HKUS-MP014V001/MS		X- RING FOR HKUS		
26	MLHP & HR-MP013V021/MS		DUST SEAL RING FOR MLHP & MLHR		
27	MLHP & HR-MP015V048-HP/MS		SHAFT SEAL RING FOR MLHP & MLHR (HIGH PRESSURE)		
28	MLHSY400-BR/MS		BEARING UNIT FOR MLHSY400G6UD		
29	MLHR160G2U1E/MS		ORBIT MOTOR		

M+S HYDRAULIC

Hydraulic Motor Low Speed High Torque

MLHM SERIES / SAE version



Code Number (OMP)	Displacement (cc/rev)	Max.Speed (rpm.) Cont.	Torque (daNm)		Pressure Drop (bar)		Shaft Dia. (mm.)	Max.Flow (Lt/min) Cont.
			Norm.	Max.	Norm.	Max.		
			MLHM 8	8.2	1,950	1.2		
MLHM 12.5	12.9	1,550	1.7	2.3	105	140	16	20
MLHM 20	20	1,000	2.6	3.5	105	140	16	20
MLHM 32	31.8	630	4.2	5.7	105	140	16	20
MLHM 40	40	500	4.2	5.7	82.5	110	16	20
MLHM 50	50	400	4.5	5.8	70	90	16	20

MLHP SERIES / SAE version



Code Number (OMP)	Displacement (cc/rev)	Max.Speed (rpm.) Cont.	Torque (daNm)		Pressure Drop (bar)		Shaft Dia. (mm.)	Max.Flow (Lt/min) Cont.
			Norm.	Max.	Norm.	Max.		
			MLHP 25	25	1,600	3.3		
MLHP 32	32	1,560	4.3	6.1	100	140	25	50
MLHP 40	40	1,515	6.2	8.2	120	155	25	60
MLHP 50	49.5	1,225	9.43	11.9	140	175	25	60
MLHP 80	79.2	765	15.15	19.5	140	175	25	60
MLHP 100	99	612	19.3	23.7	140	175	25	60
MLHP 125	123.8	489	23.7	29.8	140	175	25	60
MLHP 160	158.4	382	31.3	37.8	140	175	25	60
MLHP 200	198	306	36.6	45.6	140	175	25	60
MLHP 250	247.5	245	38	58.3	110	175	25	60
MLHP 315	316.8	1	38	56	90	140	25	60
MLHP 400	396	3	36	59	70	115	25	60
MLHP 500	495	122	39	57	60	90	25	60
MLHP 630	623.6	97	44	64	55	80	25	60



MLHR SERIES / SAE version



Code Number (OMR)	Displacement (cc/rev)	Max.Speed (rpm.) Cont.	Torque (daNm)		Pressure Drop (bar)		Shaft Dia. (mm.)	Max.Flow (Lt/min) Cont.
			Norm.	Max.	Norm.	Max.		
			MLHR 50	51.5	734	10.1		
MLHR 80	80.3	750	19.5	22	175	200	25	60.6
MLHR 100	99.8	607	24	28	175	200	25	60.6
MLHR 125	125.7	482	30	34	175	200	25	60.6
MLHR 160	159.6	379	39	43	175	200	25	60.6
MLHR 200	199.8	303	38.5	46	140	175	25	60.6
MLHR 250	250.1	240	39	58	110	175	25	60
MLHR 315	315.7	190	39	57	90	140	25	60
MLHR 400	397	152	38	60	70	115	25	60.6



M+S HYDRAULIC

Hydraulic Motor Low Speed High Torque

MLHS SERIES / SAE version



Code Number	Displacement	Max.Speed	Torque		Pressure Drop		Shaft Dia.	Max.Flow
(OMS)	(cc/rev)	(rpm.)	(daNm)		(bar)		(mm.)	(Lt/min)
		Cont.	Norm.	Max.	Norm.	Max.		Cont.
MLHS 80	80.5	810	20	24	175	210	32	65
MLHS 100	100	750	29.2	32	205	225	32	75
MLHS 125	125.7	600	37.4	41	205	225	32	75
MLHS 160	159.7	470	46	51.5	205	225	14T-12/24	75
MLHS 200	200	375	46	60	160	210	14T-12/24	75
MLHS 250	250	300	50	63	140	175	32	75
MLHS 315	314.9	240	54	63	120	140	32	75
MLHS 400	397	190	58	69	100	120	32	75
MLHS 475	474.6	160	58	68	85	100	32	75
MLHS 525	522.7	145	58	69	80	90	32	75
MLHS 565	564.9	130	58	69	75	85	32	75
MLHSY 200	200	375	56.6	64.5	200	225	32	75
MLHSY 250	250	300	70.8	80.6	200	225	32	75
MLHSY 315	314.9	240	90	96	200	225	32	75
MLHSY 400	397	185	90	97	160	175	14T-12/24	75
MLHSY 475	474.6	155	91	96	140	150	32	75

MLHT SERIES / SAE version



Code Number	Displacement	Max.Speed	Torque		Pressure Drop		Shaft Dia.	Max.Flow
(OMT)	(cc/rev)	(rpm.)	(daNm)		(bar)		(mm.)	(Lt/min)
		Cont.	Norm.	Max.	Norm.	Max.		Cont.
MLHT 160	161.1	622	47	56	200	240	40	100
MLHT 200	201.4	620	59	71	200	240	40	125
MLHT 250	251.8	496	73	88	200	240	40	125
MLHT 315	326.3	382	95	114	200	240	40	125
MLHT 400	410.9	304	108	126	180	210	40	125
MLHT 500	523.6	238	122	137	160	180	40	125
MLHT 630	631.2	197	138	155	140	160	40	125
MLHT 725	724.3	164	153	172	120	140	40	125

MLHV SERIES / SAE version



(OMV)	Displacement	Max.Speed	Torque		Pressure Drop		Shaft Dia.	Max.Flow
MLHV 315	314.5	510	92	111	200	240	50	160
MLHV 400	400.9	500	118	141	200	240	50	200
MLHV 500	499.6	400	146	176	200	240	50	200
MLHV 630	629.1	320	166	194	180	210	50	200
MLHV 800	801.8	250	188	211	160	180	50	200

M+S HYDRAULIC

Hydraulic Motor Low Speed High Torque

Hydrostatic Steering Unit Type HSKUS..../4



Code Number	Displacement	Rated Pressure	Port Size	Rated Flow
	(cc/rev)	(bar)		(Lt/min)
HKUS 40	39.6	160	G 1/2	4
HKUS 50	49.5	160	G 1/2	5
HKUS 63	65.6	160	G 1/2	6
HKUS 80	79.2	160	G 1/2	8
HKUS 100	99	160	G 1/2	10
HKUS 125	123.8	160	G 1/2	13
HKUS 160	158.4	160	G 1/2	16
HKUS 200	198	160	G 1/2	20
HKUS 250	247.5	160	G 1/2	25
HKUS 320	316.8	160	G 1/2	32
HKUS 400	396	160	G 1/2	40

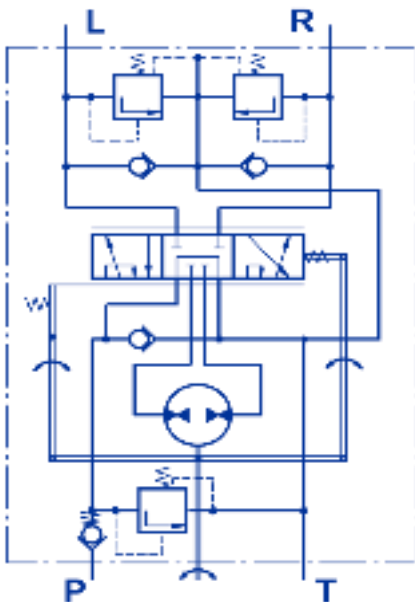

Open center Non Load Reaction with Built-In Valves